

MANDRINO A TRE GRIFFE PER TRAPANO DI PRECISIONE
TIPO INDUSTRIALE PESANTE CON CHIUSURA A CREMAGLIERA.
FORNITO COMPLETO DI CHIAVE DENTATA.

THREE-JAW CHUCKS FOR PRECISION DRILLS WITH RACK CLAMP FOR HEAVY
INDUSTRY, EQUIPED WITH TOOTHED SPANNER

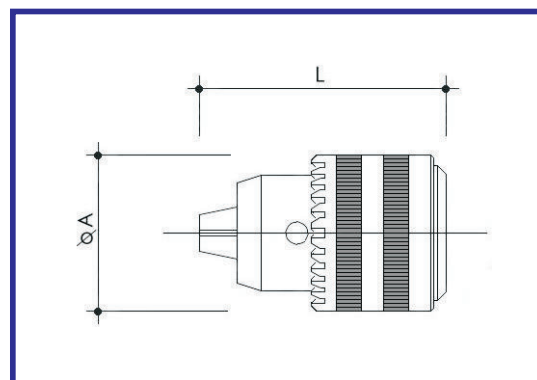
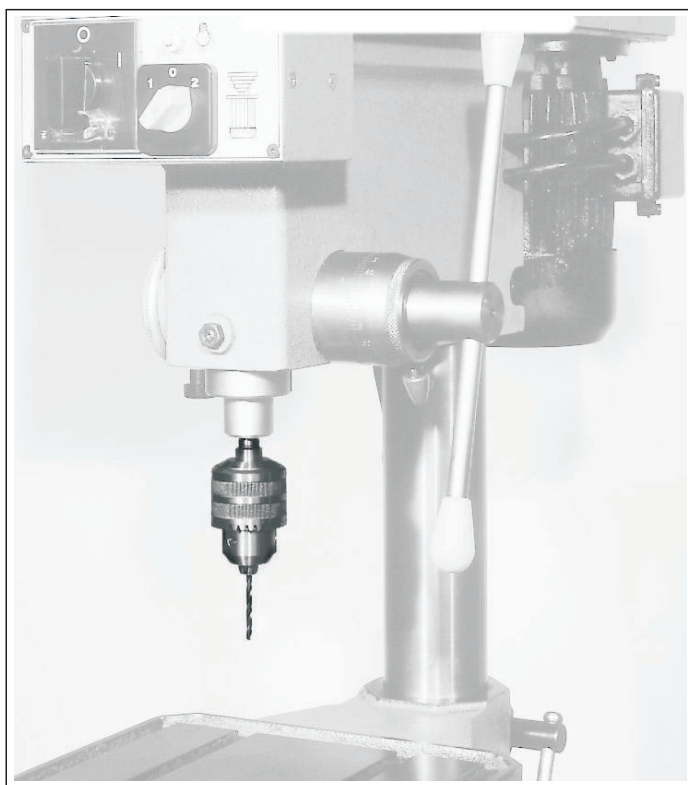

CODICE CODE	APERTURA OPENING MM	CONO CONE DIN 238/2	PESO WEIGHT Kg	CODICE CHIAVE CODE KEY	A MM	L MM
AM00300000	0+3		0,075	CRAM003R11	23,5	36
AM00400010	0+4	B10	0,100	CRAM004R12	26	46
AM00600010	0+6	B10	0,150	CRAM006R13	32	53
AM00800012	0+8	B12	0,190	CRAM008R14	34	58
AM01000016	0+10	B16	0,420	CRAM010R15	45	76
AM01300016	0+13	B16	0,750	CRAM013R16	56	90
AM31600016	3+16	B16	0,750	CRAM316R16	56	90
AM01600018	0+16	B18	1,050	CRAM016R16	62	100