

MANDRINO DI TIPO PROFESSIONALE A DUE GRIFFE PER SERRARE PUNTE, FRESE E MECCHIE PER LA LAVORAZIONE DEL LEGNO.  
 VIENE UTILIZZATO DAI PIÙ IMPORTANTI COSTRUTTORI PER ESSERE MONTATO COME PRIMO EQUIPAGGIAMENTO SULL'ALBERO DI CAVATRICI E MACCHINE COMBinate.  
 I MANDRINI POSSONO ESSERE FORNITI ANCHE CON CALOTTA DI PROTEZIONE.  
 SU RICHIESTA SI ESEGUONO MANDRINI SPECIALI CON ATTACCHI SU DISEGNO DEL CLIENTE.

PROFESSIONAL TWO-JAW CHUCK TO CHUCK DRILLS, CUTTERS AND BITS FOR WOOD-WORKING.  
 IT IS USED BY THE MOST IMPORTANT MANUFACTURES AS FIRST EQUIPMENT TO BE INSTALLED ON THE SHAFT OF MORTISING MACHINES AND WOOD-WORKING MACHINES.  
 THE CHUCKS CAN BE SUPPLIED ALSO WITH A COVER.  
 BY REQUEST IT IS POSSIBLE TO PRODUCE SPECIAL CHUCKS WITH COUPLINGS DESIGNED BY THE CUSTOMER.



STANDARD

ATTACCHI A DISEGNO - CUSTOMER'S DRAWINGS



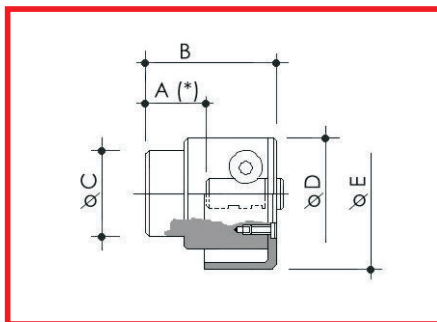

CODICE CODE	APERTURA OPENING MM	CONO CONE DIN 238/2	CHIAVE KEY Esag. Exagon	PESO WEIGHT Kg	A MM	B MM	C MM	D MM
WS01057N16	0+10	B 16	6	0,400	26	57	32	42
WS01364N16	0+13	B 16	6	0,720	32	64	40	50
WS01370N16	0+13	B 16	6	0,720	32	70	40	50
WS01670N18	0+16	B 18	7	1,020	32,5	70	44	54
WS01674N18	0+16	B 18	7	1,020	37	74,5	44	54
WS02076N22	0+20	B 22	8	1,380	36	76	50	61
WS02086N22	0+20	B 22	8	1,380	46	86	50	61
WS02693N24	0+26	B 24	8	2,100	46	93	59	70



CODICE CODE	APERTURA OPENING MM	CONO CONE DIN 238/2	CHIAVE KEY Esag. Exagon	PESO WEIGHT Kg	A MM	B MM	C MM	E MM
WS01057C16	0+10	B 16	6	0,400	26	57	32	55
WS01364C16	0+13	B 16	6	0,720	32	64	40	62
WS01370C16	0+13	B 16	6	0,720	32	70	40	62
WS01670C18	0+16	B 18	7	1,020	32,5	70	44	76
WS01674C18	0+16	B 18	7	1,020	37	74,5	44	76
WS02076C22	0+20	B 22	8	1,380	36	76	50	83
WS02086C22	0+20	B 22	8	1,380	46	86	50	83
WS02693C24	0+26	B 24	8	2,100	46	93	59	99

(\*) Misura per l'attacco a disposizione sui mandrini standard per lavorazioni speciali  
Measure for the coupling available on standard chucks for special working